

SAURER.



Best choice.
CarpetCabler CarpetTwister





Saurer Twisting Solutions is continuously setting new milestones in the development of twisting and cabling machines.

We combine innovative technology with decades of experience so that you can react reliably and confidently to the demands of an ever-changing market with our machines.

Our entrepreneurial and pioneering spirit is the driving force for further developments and innovations – for your future as well!

Contents

4
Features and benefits

6
Drive concept

8
Cross section

12
Hi-Lo creels and brakes

14
Spindle area

19
Overfeed area

20
Take-up area

21
Transport and automation

22
Technical and textile data

Features and benefits

- One drum shaft per side with individual spindle tape drive**
- The highest twist quality due to high quality yarn guide elements**
- Minimised friction losses due to optimised drive and storage technology**
- Low set-up times due to central machine adjustments**
- Low investment costs and a high degree of globally trusted reliability**
- High degree of security, with CE certification**
- Low maintenance requirements**



CarpetCabler / CarpetTwister

Our CarpetCabler and CarpetTwister twisting and cabling machines have been successfully used for decades to produce high quality, premium yarns for quality carpets and other textiles in the most economical way.

They offer optimum possibilities for reliably and confidently mastering even the most unusual requirements of an ever-changing market.

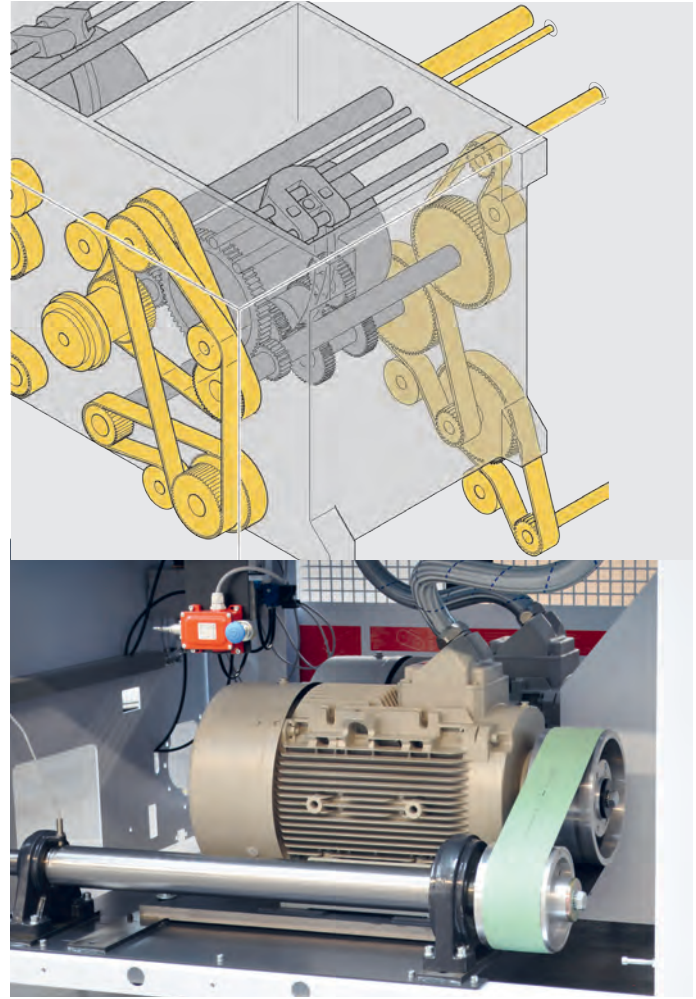

Our drive concept for high-quality yarns

Individual spindle tape drive

The universal individual spindle tape drive is designed to provide absolute reliability and ensures precisely synchronised running of all the driven spindles.

Your advantages:

- Consistent separation of the textile area from the drive area to avoid yarn contamination
- Drive power by means of a shaft assembly with drum pulleys
- Automatic spindle stop in the event of sliver runout or yarn break
- Yarn monitor
- Drive by side-separated main drive motors in the drive section

Mechanical gearbox

The solid dual cam gearbox makes different take-up speeds possible for each machine side. The robust traverse guide cam drives the traverse guide rod and realizes take-up speeds of up to 120 m/min. This area is equipped with an oil circulation system. The interference pulse of the anti-patterning device is controlled electronically. The interference pulse is only suppressed at the edge of the winding stroke, resulting in perfect take-up package edges and optimum package unwinding during further processing. Handling for setting work is practically solved. The yarn twist, crossing angle and overfeed speed are set on the freely accessible end of the machine. Both areas are designed oil-free, which makes the setting operation easier.

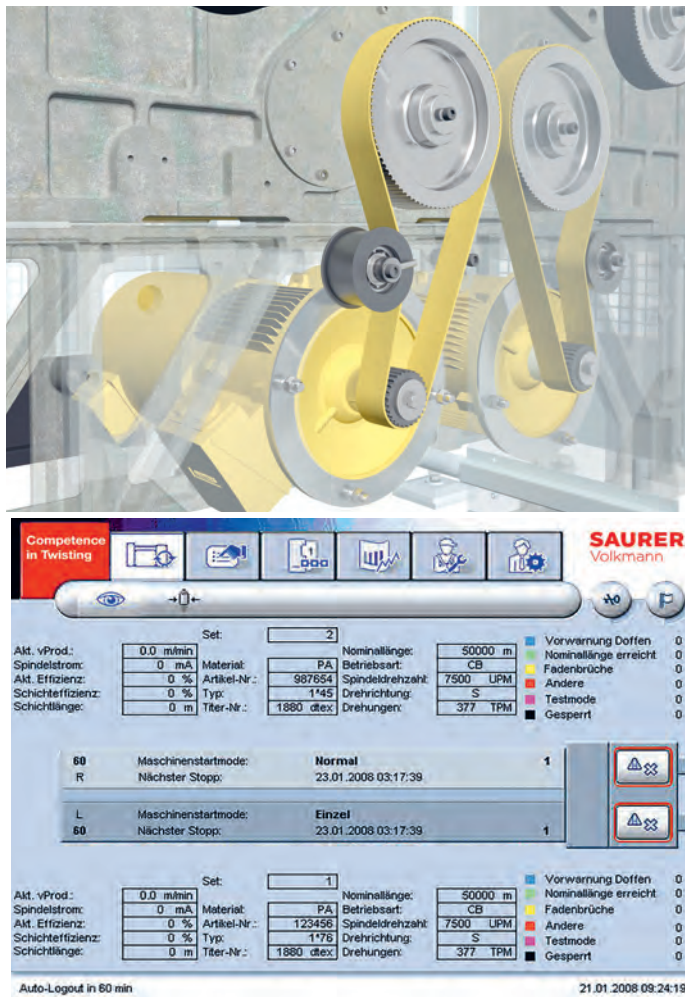

Optimum utilisation due to fast operation

Electromechanical gearbox

This computer-controlled drive system is the perfect solution to the market's requirement for fast, effective adjustment to a new yarn batch, accompanied by increased machine availability. The dual cam gearbox with solid electric motor drive in connection with frequency inverters guarantees a fast change of batch and optimum utilisation of your machine.

PowerPanel

The central operating and control unit, the PowerPanel, registers, controls and monitors the entire production process. It manages machine and batch parameters as well as your production data.

Senses

With "senses", our innovative data management system, you can take the evaluation of your key production figures to a new level. Integrated into your IT infrastructure, "senses" enables production-relevant data to be analysed and checked on any browser-enabled device.

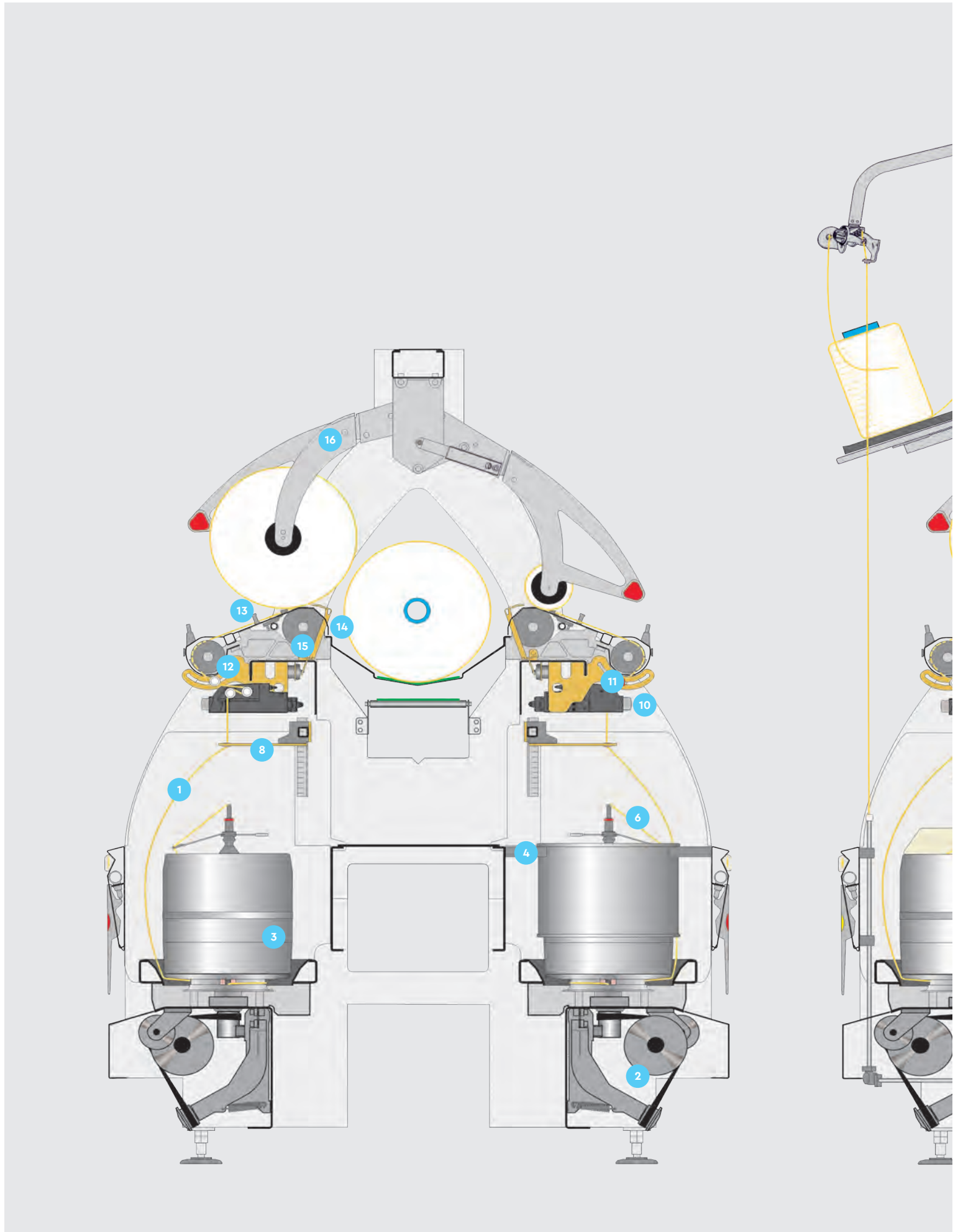

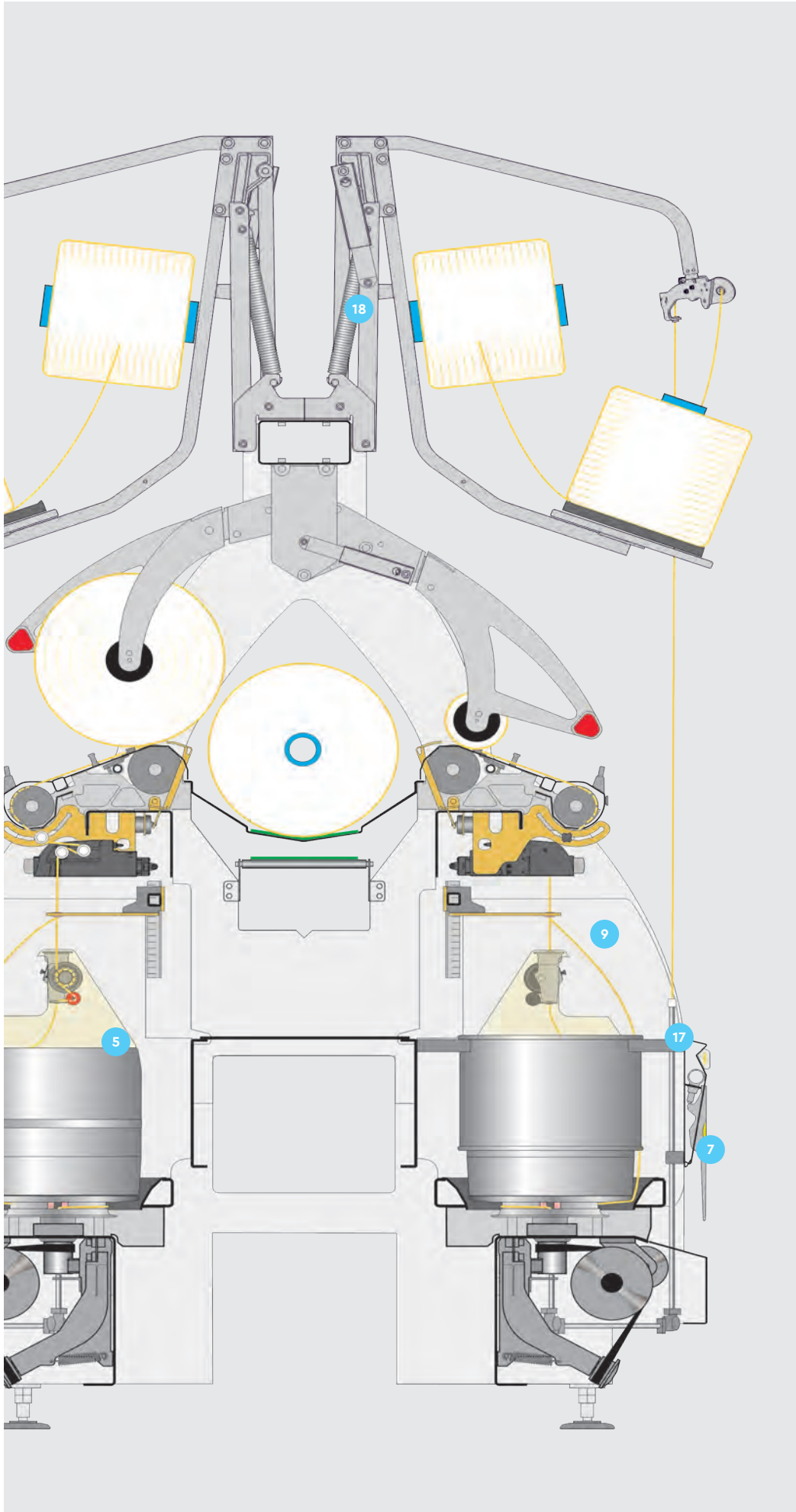

- 1 Yarn path
- 2 Individual spindle tape drive
- 3 Spindle pot
- 4 Balloon limiter
- 5 Cabling tension hood
- 6 Yarn brake and flyer
- 7 Knee lever for yarn threading
- 8 Yarn balloon guide
- 9 Separator
- 10 Differential yarn sensor
- 11 Deflection roller
- 12 Overfeed roller
- 13 Traversing mechanism
- 14 Package lifting device
- 15 Friction roller
- 16 Cradle
- 17 Yarn guide tube
- 18 Hi-Lo creel with brake

For perfect carpet yarns.





- **Delivery speed of up to 120 m/min**
- **Spindle speed up to 8.000 rpm**
- **Number of spindles up to 180 per machine**
- **Monitoring of the yarn path via pneumatic differential yarn sensor**
- **Operation via the knee lever and multifunction switch**
- **Variable drive concepts**
- **Reduction of set-up times by assembling tested sections**



Creel

Mechanical Hi-Lo creel

The spring-supported creel offers the following advantages:

- Ergonomic loading position
- Simple high-low operation
- Robust and reliable
- Automatic locking
- Optimised yarn path
- 2- or 3-peg plug-in versions
- Extra plug-in options for alternative customer requirements
- Various creel yarn brakes
- Simple operation

Pneumatic Hi-Lo creel

In addition to the advantages of the mechanical Hi-Lo creel, the pneumatic Hi-Lo creel automatically moves to the desired position after the switch is pressed.

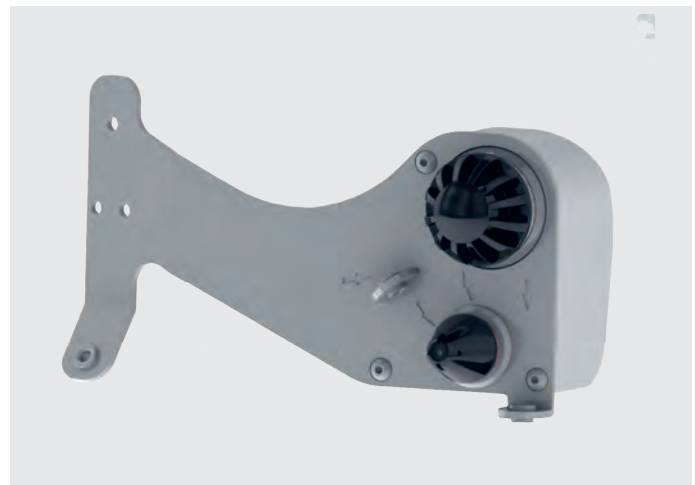
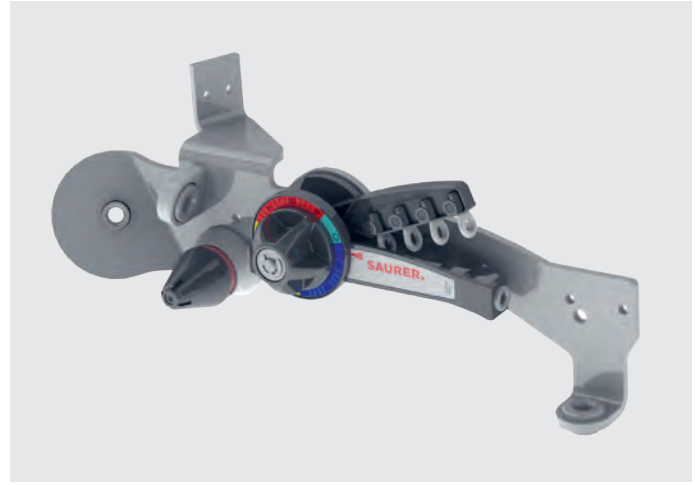
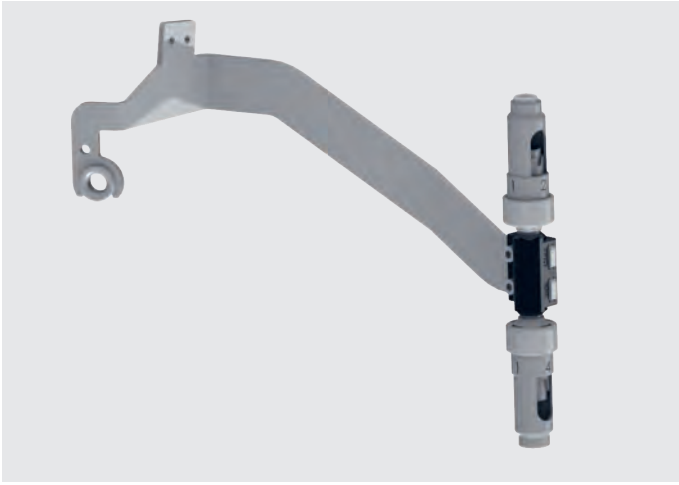

Creel yarn brakes

Capsule yarn brake

- Gradual adjustment of the tension capsules
- Precise adjustment of yarn tension
- Universally applicable
- Different brake combinations possible

Compensation brake

- Uniform yarn take-up
- Reproducible take-up forces
- Compensation of tension fluctuations in the yarn

Creel ball yarn brake

- Good simultaneous readability of the inner yarn and outer yarn brake.
- The transfer tail can be adjusted during strobe observation
- The creel does not have to be lowered (increasing machine availability)

Roller brake

- Pneumatically adjustable
- Centrally adjustable on each machine side
- Reduced conversion times
- Very even yarn take-up
- Optimum unwinding conditions
- Reproducible take-up forces
- Low yarn stress
- Good knot passage capability

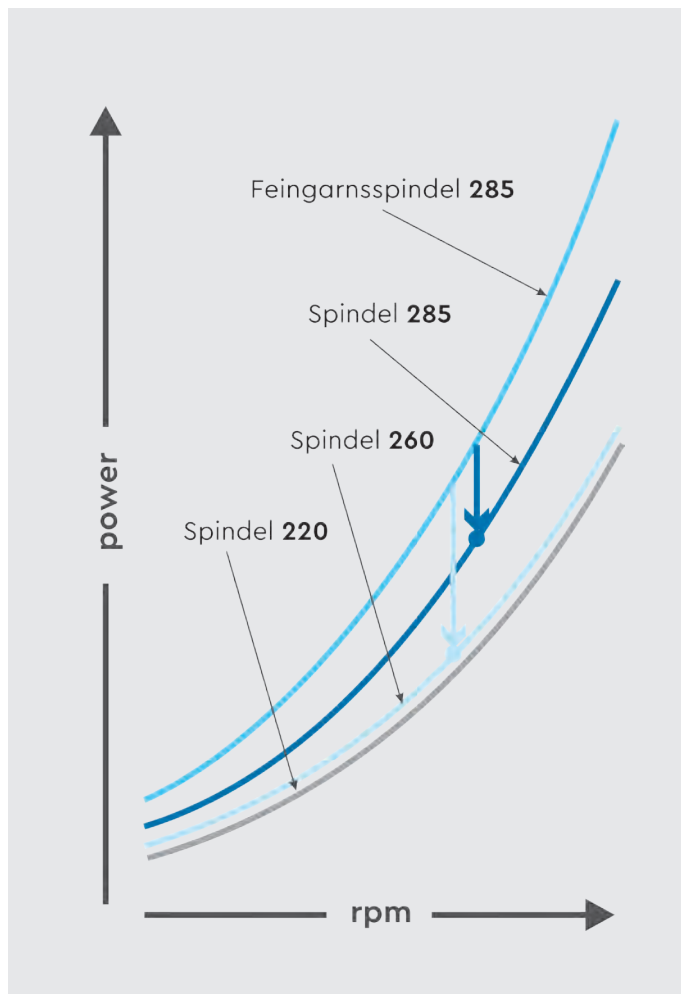

Spindle family

Fine yarn spindle 285

The fine yarn spindle for processing fine yarns can be used for both up-twisting and cabling.

Spindle 285

The energy-optimised spindle reduces energy consumption by up to 15%.

The standard feed packages can be used for up-twisting as well as for cabling. Thanks to the optimised spindle geometry, the yarn count range is suitable for all main yarn counts.

Spindle 260

With the newly optimised spindle/pot geometry, up to 35% of energy can be saved.

All major yarn counts can be processed during up-twisting and cabling and production costs can be significantly reduced.

Spindle 220

With the 220 spindle, you save up to 40% of energy, particularly with cabled yarns. This means a quantum leap in cost-effectiveness. The production process requires adapted package diameters here, which leads to an improved production sequence and ideal package sizes.

Your advantages:

- Less energy per spindle
- Reduced energy consumption per kg
- Higher production per unit area
- Optimum yarn grade
- More flexibility
- Less space required due to smaller spindles



Twisting, up-twisting or cabling

Universal hollow-shaft spindle

The universal hollow-shaft spindle of the CarpetTwister and CarpetCabler allows the two-for-one version to be easily converted to the cabling version and vice versa.

Gentle yarn guidance is ensured by high-quality, wear-resistant surfaces along the yarn path.

The ideal design of the spindle pot allows a maximum number of feed packages.

A well-balanced tension level is ensured in the yarn balloon by the reserve disc with special wear-resistant surface.



For the best possible yarn quality

The optimum combination of spindle and spindle pot in combination with brakes, unwinding aids and brake hoods represents the decisive component for the production of high-quality yarns.

Hysteresis brake

Calibrated, high-precision hysteresis brakes have been specially developed for processing carpet yarns in the direct cabling process. The quick adjustability can be easily reproduced on all hoods due to the clear readability of the brake. The hysteresis brakes guarantee a homogeneous yarn quality due to precise and high-quality, wear-resistant yarn guide elements.

Brake hood

The new brake hood can withstand even the heaviest loads thanks to the use of state-of-the-art materials.

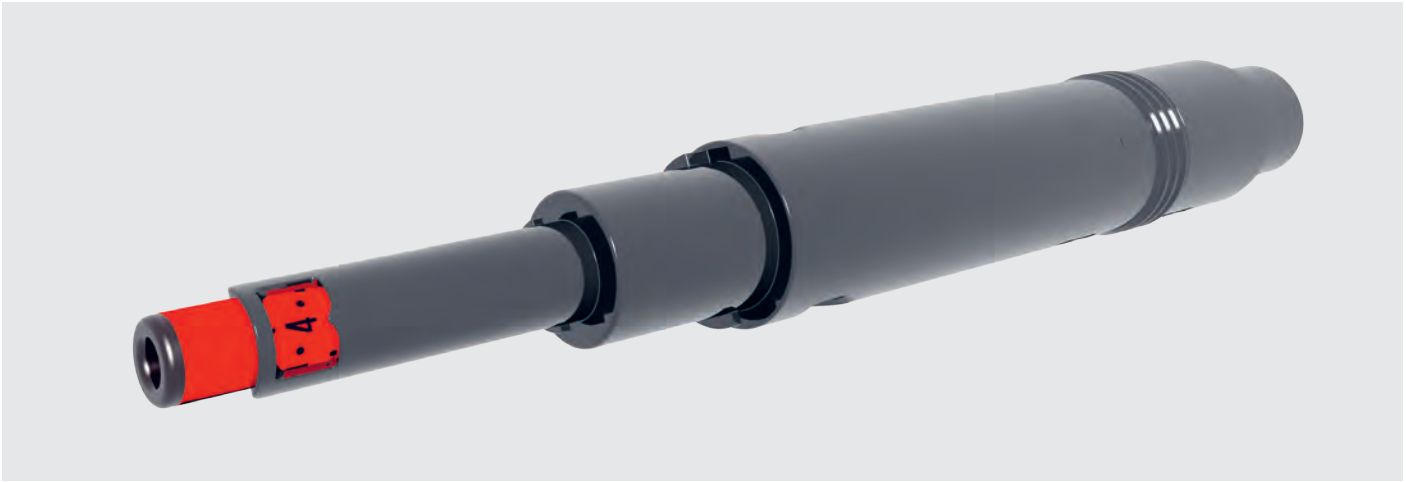

Brakes and unwinding aids

High-speed elements for up-twisting

Specially designed unwinding aids allow the processing of up-twisted articles with low amounts of twist and high take-up speeds. When an inner balloon is formed, resulting from very high unwinding speeds, the protective hood ensures that inner balloon and outer balloon are separated.

Brake

Two different pot brakes are available for the two-for-one twisting process:

The proven multi-tension device offers 5 different tension capsules for different requirements.

The ball yarn brake covers the entire yarn tension range with the wear-resistant ceramic ball. A simple turn of the inlet tube quickly adjusts the braking force over 24 levels.

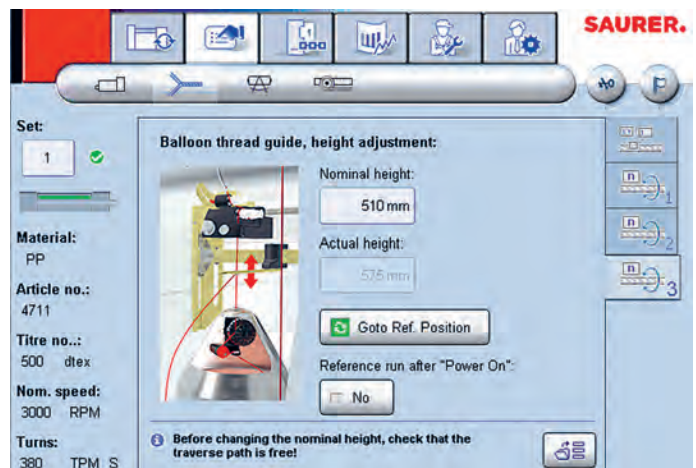
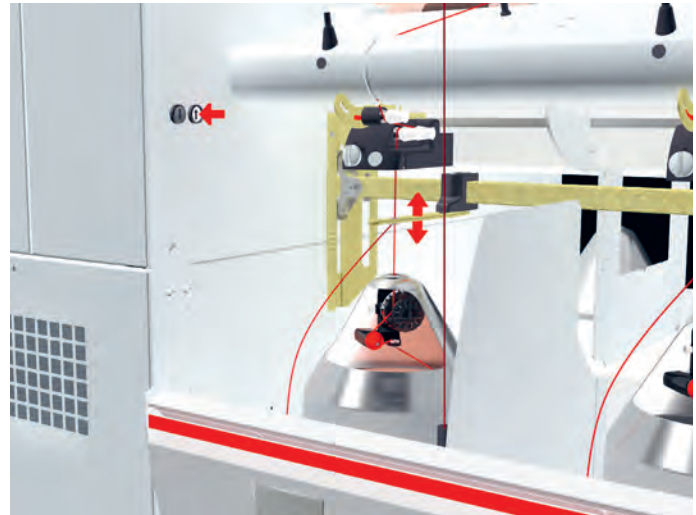
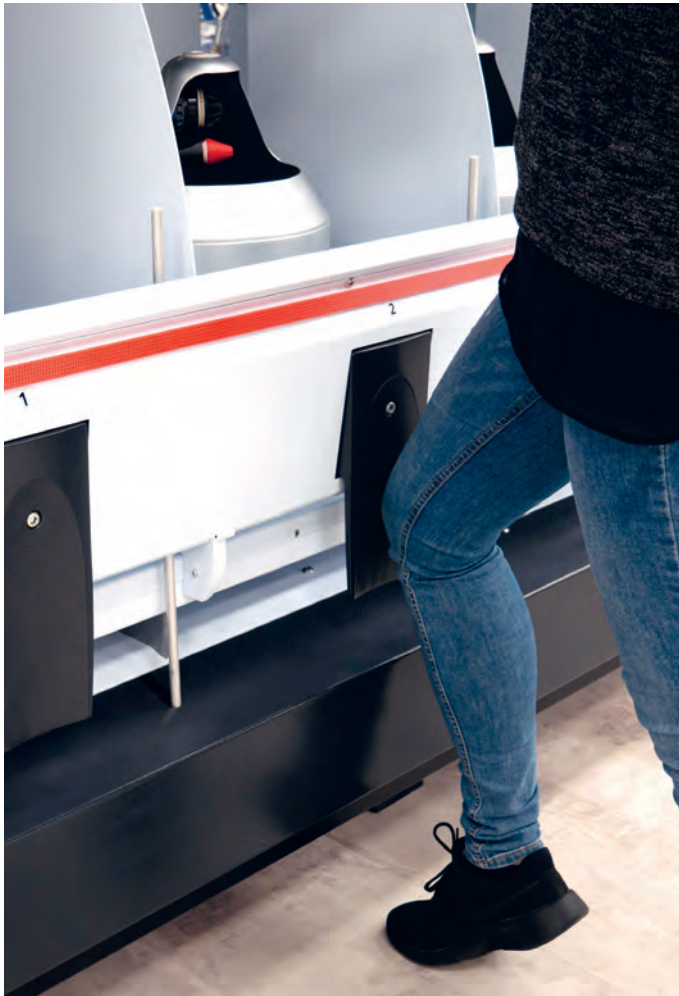

Optimised operation – easy handling

Tried and tested for decades, these Creel-Jet and Volcojet pneumatic threading systems are activated by means of a knee lever. They make a significant contribution to reducing the operating time.

Centrally adjustable yarn balloon guide

An optimum, uniform height position on all yarn balloon guides results in optimum, low energy consumption of the spindles.

- Centrally adjustable on each machine side
- Fast, simple and precise motor-driven drive for an optimum height position
- Energy saving through optimal yarn balloon
- Fast, reproducible setting through data storage in the PowerPanel

**Overfeed roller**

Depending on the wrap-around angle, the pre-take-up roller reduces the balloon tension to the desired take-up tension. The overfeed covers enable safe working and additionally carry the yarn clamp and the storage pin for easy intermediate storage of unwinding aids.

Yarn path monitoring with integrated clamping-cutting device

The yarn path is continuously monitored. In the event of a yarn break, this is clearly visibly signalled, the second yarn is clamped and cut, and ancillary functions such as spindle stop and take-up package lift-off are activated.

Your advantages:

- No losses due to broken-up yarn ends
- Avoidance of lap formations on the overfeed shaft
- Defined position of the yarn end
- Central adjustment on each machine side

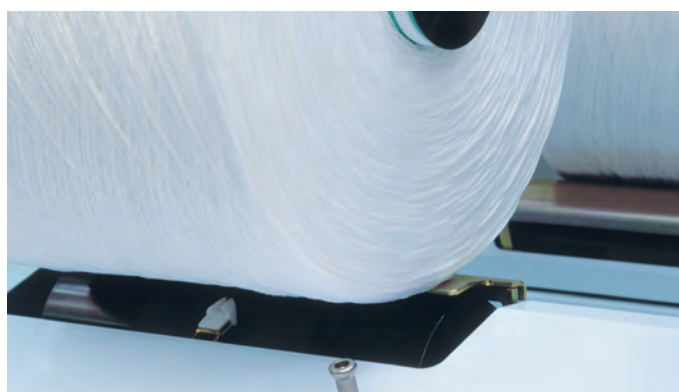

Take-up area

Cradle

High take-up speeds are possible due to the four-joint cradle. Packages with a max. diameter of 400 mm can be produced. A contact pressure adjustment system ensures a uniform winding density.

Centring discs

Easily replaceable and dirt-resistant centring discs mounted on ball pins allow simple and fast change-overs on various tube or cone types.

Package lifting device

With this accessory, the spindle is automatically stopped when a feed package comes to its end or in the event of a yarn break. After a delay, a paddle lifts the cross-package from the friction roller and stops it.

This prevents rubbing on the wound yarn surface and safeguards the original quality of the cross-package.

These functions are triggered automatically by the yarn path monitor.



Conveyor belt

Package conveyor belt

The conveyor belt conveys the finished cross-packages to the end of the machine without damaging the yarn. The ergonomically optimised belt exit point enables the cross-packages to be removed at the side. This enhancement results in a further reduction in operating times and easier operator workloads when handling large volumes of yarn. The package conveyor belt can also be used as an interim storage facility for cross-packages. A light barrier at the end of the conveyor belt allows packages to be removed in cycles.

The handling times are significantly shorter and the packages can be supplied for further processing faster. Either manually, or with our new automation system.

Automation

With our innovative FlexFlow system, we offer individual solutions for your package transport, tailored to your needs:

- Simple
- Fast
- Optimised use of personnel

Machine dimensions

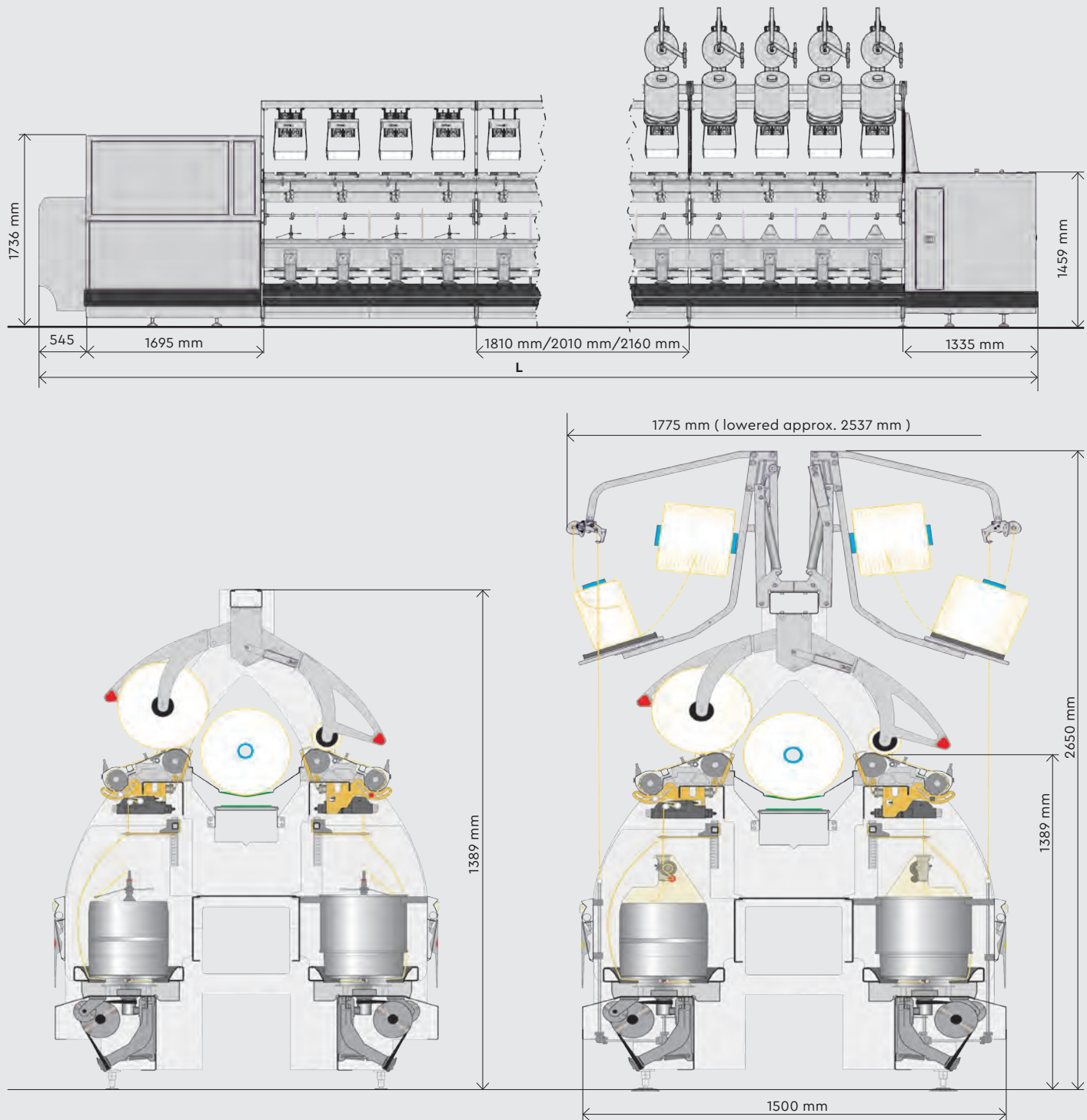

General note:

Research and development do not stand still. This can mean that one or another statement about our products is superseded by technical progress. The illustrations have been selected according to informative aspects. They can also contain optional additional equipment that is not included in the standard scope of delivery. Our technical details in the offer and order confirmation are decisive for the binding machine design.

Technical and textile data

Machine lengths spindle gauge 355, VTS-05 /-05-C

Number of spindles	12	24	36	48	60	72	84	96	108	120	132
Machine length mm	5,734	7,894	10,054	12,214	14,374	16,534	18,694	20,854	23,014	25,174	27,334
Number of spindles	144	156	168	180							
Machine length mm	29,494	31,654	33,814	35,974							

Spindle gauge 445, VTS-05-0-F /-05-0-C-F

Number of spindles	8	16	24	32	40	48	56	64	72	80	88
Machine length mm	5,384	7,194	9,004	10,814	12,624	14,434	16,224	18,054	19,864	21,674	23,484
Number of spindles	96	104	112	120	128	136	144	152	160	168	176
Machine length mm	25,294	27,104	28,914	30,724	32,534	34,344	36,154	37,964	39,774	41,584	43,394

Spindle gauge 495, VTS-05-0 /-05-0-C

Number of spindles	8	16	24	32	40	48	56	64	72	80	88
Machine length mm	5,584	7,594	9,604	11,614	13,624	15,634	17,644	19,654	21,664	23,674	25,684
Number of spindles	96	104	112	120	128	136	144	152	160	168	176
Machine length mm	27,694	29,704	31,714	33,724	35,734	37,744	39,754	41,764	43,774	45,784	47,794

Twist range:	Cabling	21 to 355 t/m
	Twisting	41 to 710 t/m
Yarn count range:	Cabling	500 to 5,000 dtex
(depending on spindle type)	Twisting	Nm 2/2 to 28/2
Spindle speed:	up to 8,000 rpm	
Take-up speed:	Max. 150 m/min	

The overview shows an overall working range, depending on the machine specification there may be restrictions.

Packages	Creel package	Pot feed package spindle 285	Pot feed package spindle 260	Pot feed package spindle 220	Cylindrical take-up package	Tapered take-up package
Winding stroke:	254 mm	254 mm	254 mm	254 mm	254 mm	254 mm
Max. package diameter:	285 mm	285 mm	255 mm	220 mm	400 mm	400 mm
Max. tube length:	290 mm	290 mm	290 mm	290 mm	290 mm	290 mm
Min. inner tube diameter:	73 mm	73 mm	73 mm	73 mm	73 mm	33 mm
Net yarn weight:	approx. 5.5 kg	approx. 5.5 kg	approx. 4.8 kg	approx. 3.3 kg		

Optional additional devices:

The optional additional devices not included in the standard scope of delivery of the machine are:

Volcojet, Creel-Jet, conveyor belt, central adjustment of yarn balloon guide, add-on balloon limiter, various brakes, adapters and unwinding aids, lubrication system, Senses,

Saurer Technologies GmbH & Co. KG
Twisting Solutions
Weeserweg 60
47804 Krefeld
Germany
T +49 2151 717 01
sales.twisting@saurer.com

Saurer Technologies GmbH & Co. KG
Twisting Solutions
Leonhardstrasse 19
87437 Kempten
Germany
T +49 831 688 0
sales.twisting@saurer.com

Saurer Hong Kong
Machinery Co. Ltd.
Room 2803-5, 28/f, The Center
99 Queen's Road Central
Central
Hong Kong
T +852 2866 0308
jackson.ye@saurer.com

Saurer (Jiangsu)
Textile Machinery Co., Ltd.
Shanghai Branch Company
36F, Tower B, The HQ, 100 Zunyi Road
200051 Shanghai
China
T +86 21 2226 2578
TWI.SH.CN@saurer.com

Saurer (Jiangsu)
Textile Machinery Co., Ltd.
No.9, Chang Yang Street
Suzhou Industrial Park, 215024
Jiangsu Province
China
T +86 512 8188 5688
info.TWI.CN@saurer.com

Saurer Inc.
8801 South Boulevard
Charlotte, NC 28273
USA
T +1 704 916 42 72
Twisting.USA@saurer.com

saurer.com