

SAURER.



Cutting-edge.

CableCorder CC5





For many years, Saurer Twisting Solutions has regularly defined benchmarks for twisting and cabling machines.

At our site in Kempten, we develop forward-looking technologies for the energy-efficient production of tire cord and technical yarns.

As a reliable partner, we create intelligent and economical solutions for the individual needs of our customers.

Our entrepreneurial and pioneering spirit is the driving force for further developments and innovations – for your future as well.

Contents

4

CableCorder CC5
Features and benefits

6

Machine cross section

8

Innovative thinking –
pioneering spirit

10

Reducing energy
consumption and costs

11

Economical across the
board

12

Optimum twist quality

14

Simple operation – best
results

15

Intelligent solutions for
automation

16

E³ – Energy, Economics,
Ergonomics

18

The right machine for
every need

20

Technical and textile data

Features and benefits

- High energy savings thanks to outer yarn delivery system and slim balloon technology**
- More spindles over the same machine length**
- Smart spindle design with optimised, user-friendly components**
- Reduced yarn waste and low maintenance costs**
- High-quality tire cord thanks to innovative quality sensor**
- Higher production speed**
- Variability and variety due to variants for two-for-one twisting and 3-ply cabling**
- Versatile and individual automation solutions possible**



CableCorder CC5 – Cabling in pole position

The CableCorder CC5 marks what is now the fifth generation of successful direct cabling machines for tire cord and technical yarns from our company. With numerous innovations, it once again demonstrates its technological leadership and the associated customer benefits. Our customers benefit economically from a coherent overall package consisting of a smart spindle concept, modern quality monitoring, improved ergonomics and both individual and flexible solutions for automation and data management.

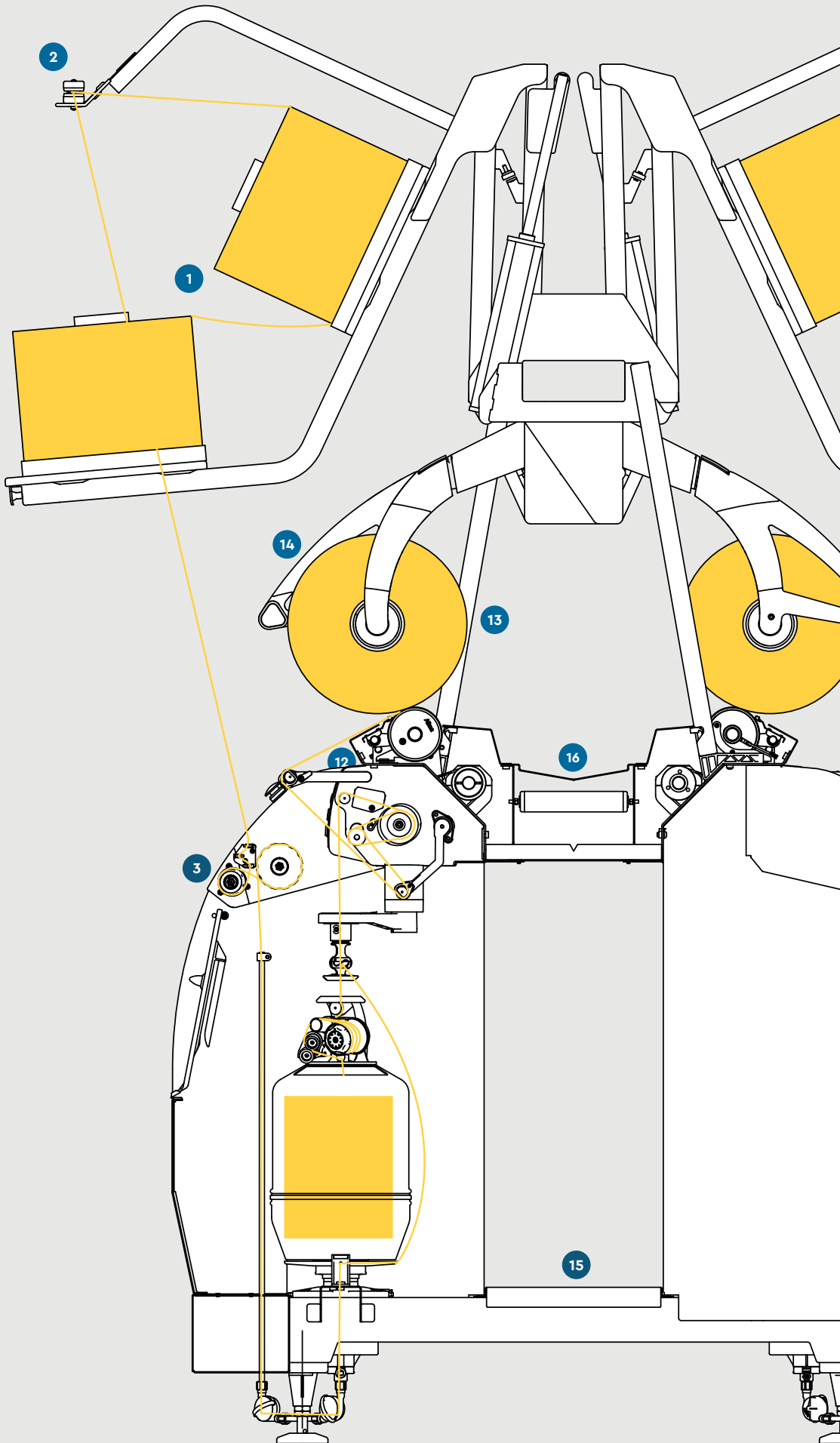

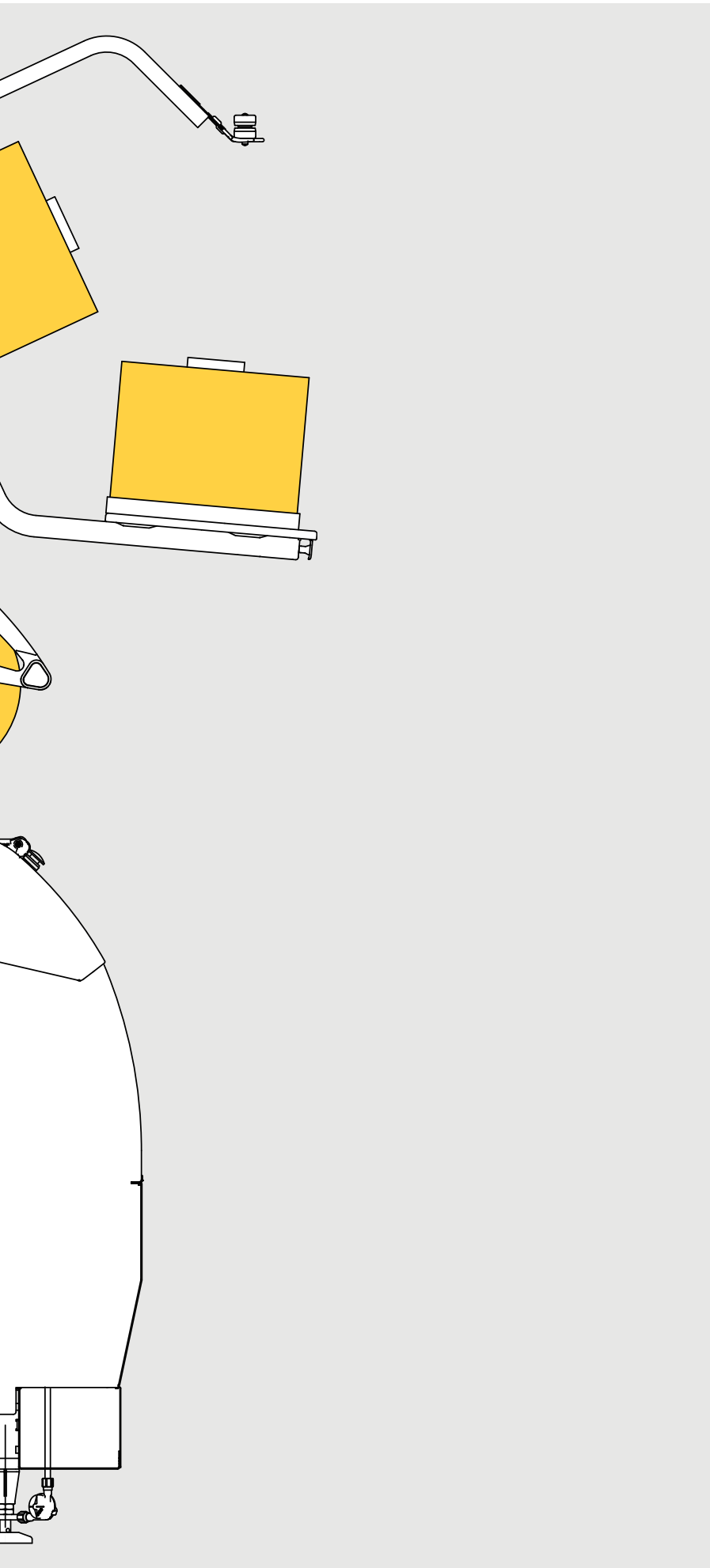

- **1** Feed package and reserve package
- **2** Pretensioner in creel
- **3** Outer yarn tensioner (CC5-Basic)
- **4** Outer yarn delivery system (CC5)
- **5** Air threading
- **6** Motor spindle
- **7** Spindle pot / Feed package
- **8** Thread balloon
- **9** Inner yarn tensioner
- **10** Cord Regulator
- **11** Capstan with quality sensor
- **12** Traverse motion / Winding roller
- **13** Twist package
- **14** 4-hinge package cradle
- **15** Suction unit
- **16** Conveyor belt



Innovative thinking – pioneering spirit

As a market and innovation leader, we see it as our duty to offer our customers solutions with which they can confidently and successfully meet the challenges of the future. With the CableCorder CC5, you are well prepared for future developments.

Drive concept

The CableCorder CC5 has a single spindle drive with frequency inverter technology which is controlled by a modern data bus system.

Extended production processes

The CableCorder CC5 is available as "3PLY" variant for producing symmetrical 3-ply tire cord. Here, our customers benefit from the machine's high cost-effectiveness and simple handling. We offer the "TFO" variant for processing yarns in the two-for-one twisting process. The main advantage here is the high delivery speed of up to 150 m/min.

We are meeting the increased demand from the market for hybrid yarns with both the cabling and two-for-one twisting processes.

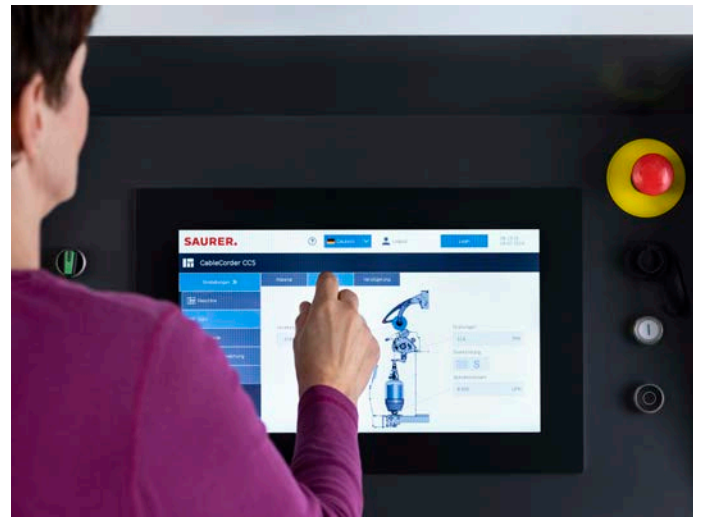

Spindle design and yarn guidance

We develop solutions that give our customers the added value they need. Newly developed machine components such as spindle pot, Cord Regulator and capstan set innovative standards in yarn guidance.

Maximum quality is indispensable

Tire cord is rightly expected to meet the highest standards, because it must be extremely resilient and guarantee the best possible safety. Online monitoring of the quality parameters with our newly developed quality sensor reliably ensures the required quality.

Data exchange and communication

The communication interface complies with the OPC UA standard and thus meets the technical requirements for networking with other system components. The CableCorder CC5 is thus equipped for incorporation into Industry 4.0 environments.

Control panel (HMI) with multitouch technology

With the new control panel and the completely revised user interface, controlling and setting of machine parameters has been made even more intuitive and faster. The operator receives all information required for the operation of the machine.

Senses

The innovative mill management system Senses (option) collects and analyses all relevant production, quality and machine data. The valuable data can be called up on devices using a web browser – even when on the move.



Reducing energy consumption and costs

A core element of the development concept for the CableCorder is the consistent reduction in the energy required, compared to the previous generation. We have also remained true to this concept in the fifth generation. In this way, we give our customers the opportunity to improve significantly the profitability of their production.

Slim balloon technology

In addition to the proven and patented energy-saving technology of the previous machine generation, the CableCorder CC5 offers even more possibilities to reduce energy consumption. Slim balloon technology not only increases economic efficiency by reducing operating costs, but also process reliability.

New energy-saving pots

The spindles for feed packages 230 and 250 of the CableCorder CC5 are equipped with newly developed energy-saving pots. This makes it possible to reduce the size of the yarn balloon and thus the energy consumption.

Stopping the drives

After the twist packages have been completed, all drives enter a predefined standby mode without delay.



Economical across the board

Same machine length – more spindles

The CableCorder CC5 with spindle gauge 400 is available with up to 200 spindles. Compared to the previous model, this means an increase of 32 spindles for the same overall length.

Reduced yarn waste

With the CableCorder CC5, yarn waste is significantly reduced by intelligent process control. Optimum package building in conjunction with precise length measurement ensures low waste during further processing, while permanent sensor-controlled monitoring of the process parameters ensures consistently high yarn quality. The CableCorder CC5 is equipped with a UPS (option) to make sure this takes place, even in the event of mains power fluctuations and/or power cuts.

Always at the optimum speed

The production speed can be individually adapted to the respective requirements. This also increases productivity and thus profitability.

Low maintenance requirements

The well-known solid construction in combination with use of high-quality components form the basis for a long, productive machine life. The maintenance work involved has been significantly reduced by completely redesigned assemblies such as the Cord Regulator. The Maintenance Indicator (option) – also a product innovation – provides information about the right time for maintenance or service work.

Performance Indicator

The optional Performance Indicator monitors the power consumption of the machine. The insights gained in this way help to optimise machine performance.

Air threading

With air threading, the threading operation is easier than ever before – and that with constant air consumption.

Optimum twist quality.

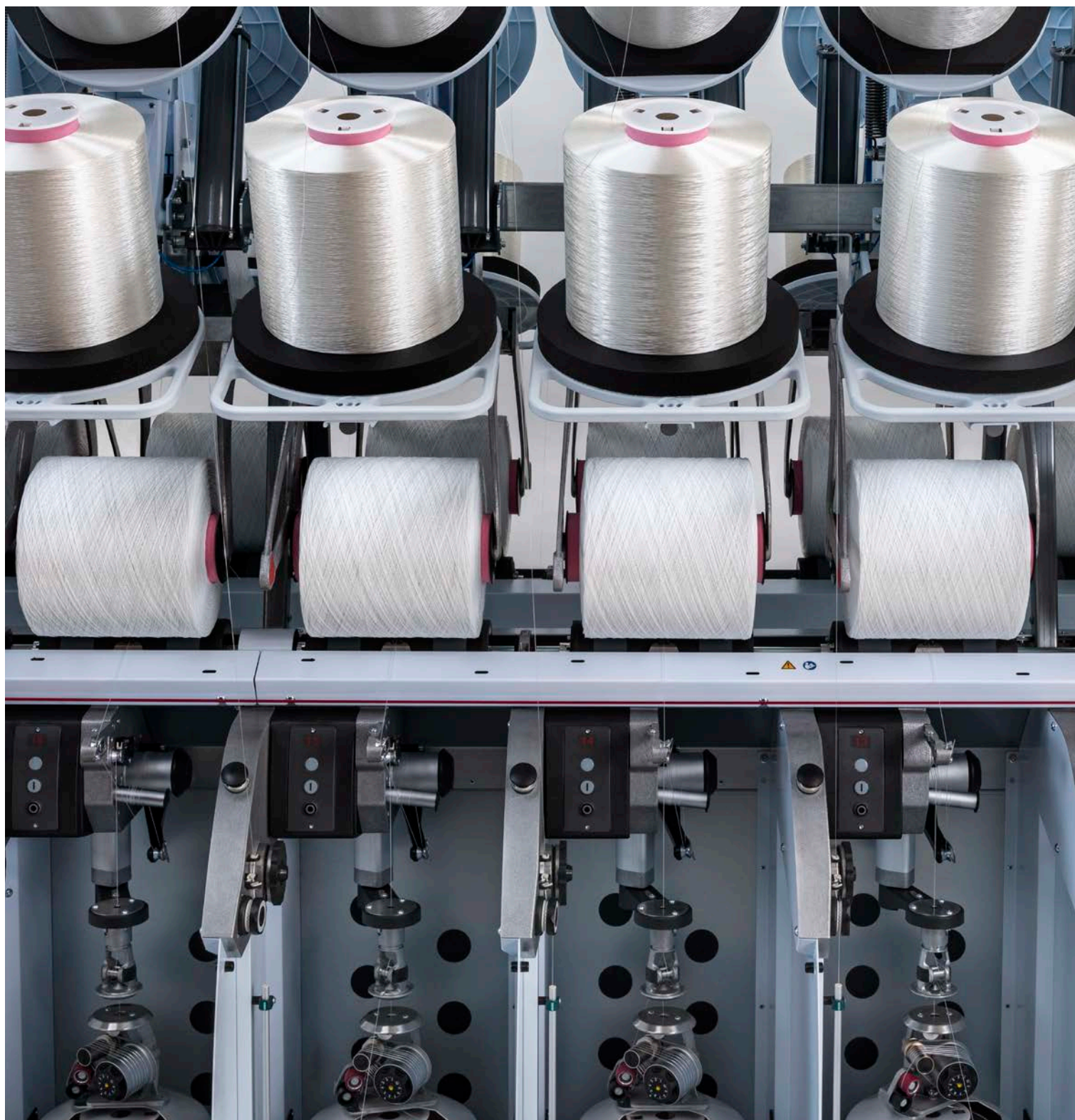



- **Reliable process with optimised yarn path**
- **Perfect build-up of the twist package for optimum unwinding characteristics**
- **Use of yarn-friendly and wear-resistant surfaces, and specially treated yarn guiding elements**
- **Quality sensor with intelligent software for detecting yarn defects**
- **Patented outer yarn delivery system minimises yarn breaks and reduces the number of short packages**
- **Superior Cord Regulator technology ensures equal lengths of individual yarns**
- **Simple and safe operation of the twisting position**



Simple operation – best results

Optimum yarn path

The new yarn path and the optimised arrangement of the yarn guiding elements deliver convincing results due to their convenient handling and allow you to work efficiently at the twisting position.

Cord Regulator

Optimum cord properties result from a perfect interplay of yarn-protecting guidance by means of well adapted surfaces of the yarn guiding elements and equal yarn tensions of outer and inner yarn thanks to precisely calibrated and correctly adjusted inner yarn tensioners. The Cord Regulator ensures further uniformity of tension and thus equal lengths of inner and outer yarn as well as a stable twist triangle, thus ensuring high cord quality. The reliable yarn guidance in the Cord Regulator leads to a faultless yarn path. Once threaded, it is no longer necessary to rethread over many package changes.

Servo-assisted HiLo creel

The optional servo-assisted HiLo creel provides the operator with an ergonomically optimal loading position.

Package conveyor belt

Transport of the finished cross-wound packages to the end of the machine. There they can be conveniently removed. Connection to an automation system is also possible.



Intelligent solutions for automation

Increasing efficiency also plays a decisive role in the manufacture of tire cord. Process automation helps to reduce operating costs. In conjunction with the CableCorder CC5, fully or semi-automatic transport systems ensure a clean and efficient production process and reduce the strain on operating personnel.

Saurer Twisting Solutions offers a wide range of automation solutions for package transport tailored to individual customer requirements.

Our engineers will be happy to develop a concept to meet your needs.

Increased customer benefit

Energy savings, increased efficiency and more ergonomic operation are the main arguments for investing in new machines and systems. The E³ label stands for the full implementation of these aspects.

The CableCorder CC5 also steps up to the mark, as its modern concept and diverse features create added value on all these levels.

Optimised energy efficiency

Reduced energy consumption compared to the previous machine generation results from a multitude of innovative details and technical solutions having been added to proven and perfected technologies. Slim balloon technology reduces energy consumption and increases process reliability at the same time. The newly developed energy-saving pots also make a significant contribution to reducing energy consumption.

High efficiency

Depending on the spindle gauge, the CableCorder CC5 is available with up to 200 spindles per machine. The reduced use of production area resulting from this increases the economic efficiency of the plant. Intelligent software solutions for optimum package building and precise length measurement contribute to reducing material losses in the subsequent processes. The continuous monitoring of the relevant process parameters ensures consistently high product quality. In combination with the increased production speed and significantly reduced maintenance work, this results in a cabling machine of enormous economic efficiency.

Improved ergonomics

The excellent and particularly ergonomically designed operation reduces operating times and optimises work processes. The optional servo-assisted HiLo creel makes it possible to change the feed packages with little physical effort. This added value can be further increased by the optional automation of the package transport.

E³ Energy Economics Ergonomics

Energy

Optimised energy efficiency

- Slim balloon technology
- Energy-saving pots
- Software for energy management

Economics

High efficiency

- Higher production speed
- Spindle gauge 400 with 200 spindles per machine
- Quality sensor with intelligent software
- Reduced yarn waste
- Lower maintenance requirements

Ergonomics

Improved ergonomics

- Servo-assisted HiLo creel (option)
- Optimised threading process
- User-friendly yarn path
- Clearly structured operating menu

Triple Added Value

With our customers' needs always top of mind, we ensure that our products deliver optimised energy consumption, economics and ergonomics, with a focus on intelligence. This E³ principle forms the basis of our design philosophy. Our passion for textile machinery drives us to manufacture innovative products that add value to our clients' businesses.

Energy consumption CC3/CC4/CC5

PES 1670 dtexx1x2
230/10", 9400 min⁻¹

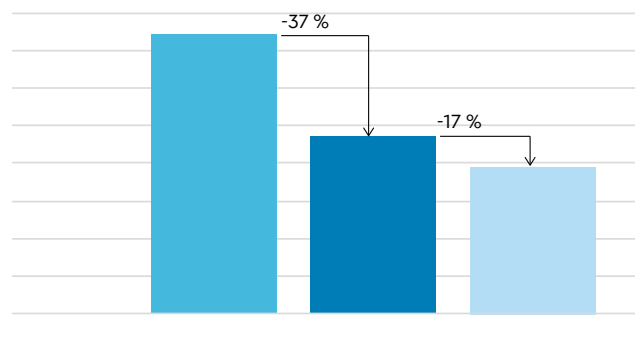

Energy consumption CC3/CC4/CC5

PES 1670 dtexx1x2
250/10", 9200 min⁻¹

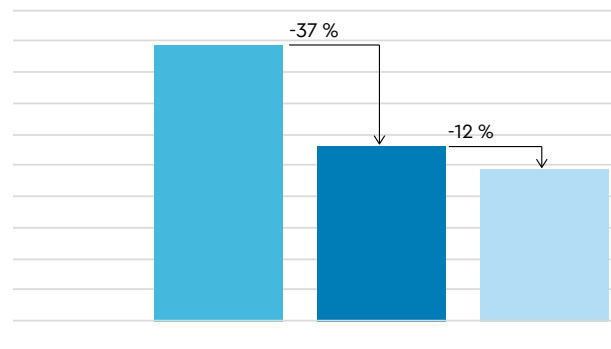

- CC3
- CC4
- CC5



The right machine for every need

CableCorder CC5

The CableCorder CC5 is a direct cabling machine for manufacturing 2-ply tire cord and industrial yarns. It is equipped with an outer yarn delivery system.

CableCorder CC5-Basic

Like the CableCorder CC5, the "Basic" version is a direct cabling machine for producing 2-ply tire cord and industrial yarns. However, the "Basic" version does not have an outer yarn delivery system.



CableCorder CC5-3PLY

The "3PLY" machine variant is a direct cabling machine for manufacturing symmetrical 2-ply and 3-ply structures.

CableCorder CC5-TFO

The "TFO" machine variant is a two-for-one twister for twisting single yarns as well as manufacturing symmetrical and asymmetrical 2-ply and 3-ply structures.

CableCorder CC5 – Machine dimensions

CableCorder CC5, CC5-Basic, CC5-3PLY

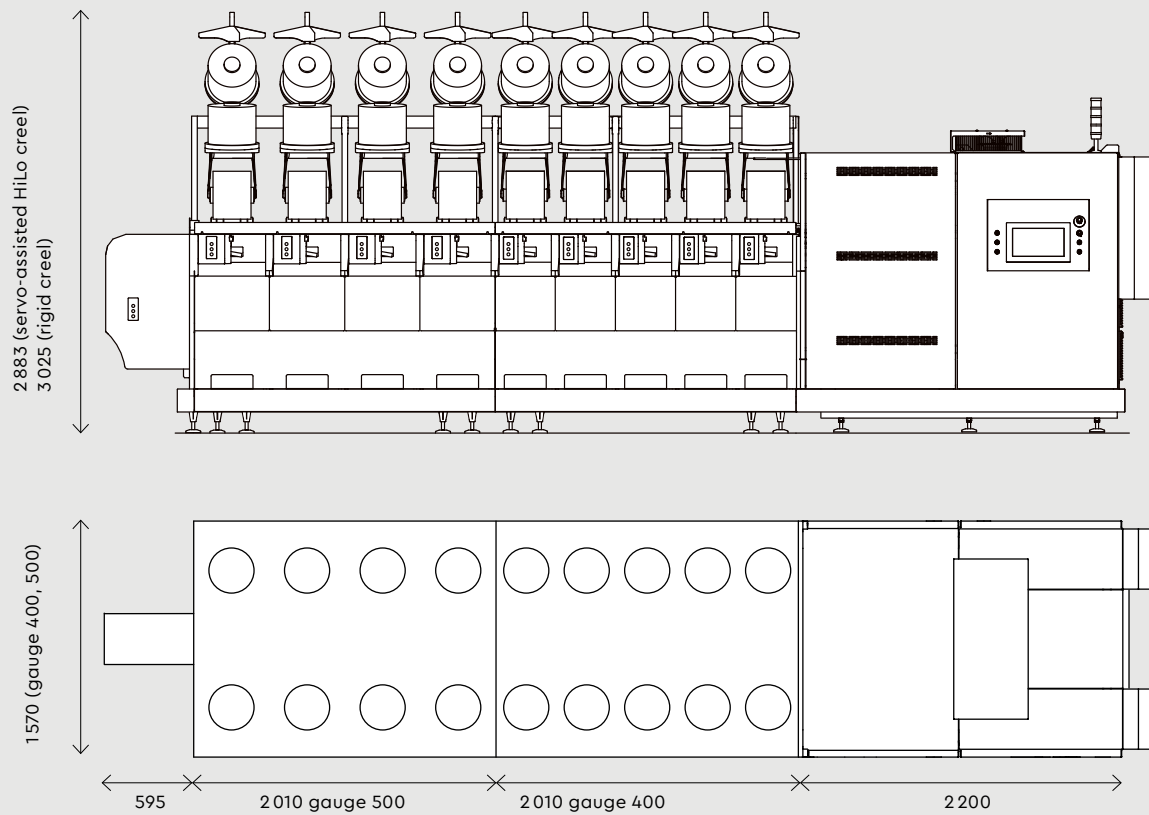

CableCorder CC5, CC5-3PLY – gauge 400

Number of spindles	10	20	30	40	50	60	70	80	90	100	110
Machine length mm	4 805	6 815	8 825	10 835	12 845	14 855	16 865	18 875	20 885	22 895	24 905
Number of spindles	120	130	140	150	160	170	180	190	200		
Machine length mm	26 915	28 925	30 935	32 945	34 955	36 965	38 975	40 985	42 995		

CableCorder CC5, CC5-Basic, CC5-3PLY – gauge 500

Number of spindles	8	16	24	32	40	48	56	64	72	80	88
Machine length mm	4 805	6 815	8 825	10 835	12 845	14 855	16 865	18 875	20 885	22 895	24 905
Number of spindles	96	104	112	120	128	136	144	152	160		
Machine length mm	26 915	28 925	30 935	32 945	34 955	36 965	38 975	40 985	42 995		

Machine lengths without dimensions of cooling units; machine length with suction duct upwards: +700 mm per suction tower
With package slide option +395 mm

CableCorder CC5 – Technical and textile data

		CableCorder CC5 – gauge 400	CableCorder CC5 – gauge 500
Spindle sizes	mm Ø/traverse	205/10", 205/12", 230/10" (E), 230/12" (E), 250/10" (E), 250/12" (E)	290/10", 290/12"
Number of spindles	max.	200	160
Spindle speed	rpm max.	2 000–11 900	
Range of twists	tpm	34–1 487	
Direction of twist		S or Z	
Delivery speed	m/min	8–60	
Materials		PA, PES, AR, CV (PES-HMLS, AR and CV with additional device)	
Range of counts	dtex	940 × 2–4 400 × 2 (depending on spindle size and gauge)	
		CableCorder CC5-Basic – gauge 500	
Spindle sizes	mm Ø/traverse	205/10", 205/12", 230/10" (E), 230/10" (F), 230/12"(E), 250/10" (E), 250/12" (E), 290/10", 290/12"	
Number of spindles	max.	160	
Spindle speed	rpm max.	2 000–11 900	
Range of twists	tpm	34–1 487	
Direction of twist		S or Z	
Delivery speed	m/min	8–60	
Materials		PA, PES, AR, CV (PES-HMLS, AR and CV with additional device)	
Range of counts	dtex	235 × 2–2 520 × 2 (depending on spindle size and gauge)	
		CableCorder CC5-3PLY – gauge 400	CableCorder CC5-3PLY – gauge 500
Spindle sizes	mm Ø/traverse	205/10", 205/12", 230/10" (E), 230/12" (E), 250/10" (E), 250/12" (E)	290/10", 290/12"
Number of spindles	max.	200	160
Spindle speed	rpm max.	2 000–11 900	
Range of twists	tpm	34–1 487	
Direction of twist		S or Z	
Delivery speed	m/min	8–60	
Materials		PA, PES, AR, CV (PES-HMLS, AR and CV with additional device)	
Range of counts	dtex	940 × 3–2 200 × 3 (depending on spindle size and gauge)	

(E)=Energy saving pot; (F)=Fine yarn count spindle

Additional devices:

Data interface OPC UA, quality sensor, servo-assisted HiLo creel, package slide, air/water or air/refrigerant heat exchanger, noise abatement, suction upwards or downwards, equipment for processing rayon and aramid, thread reserve, UPS (CC5-Basic), remote diagnostics, Performance Indicator, Maintenance Indicator, Mill Management System Senses, tension meter, stroboscope, splicer

CableCorder CC5 – Machine dimensions

CableCorder CC5-TFO

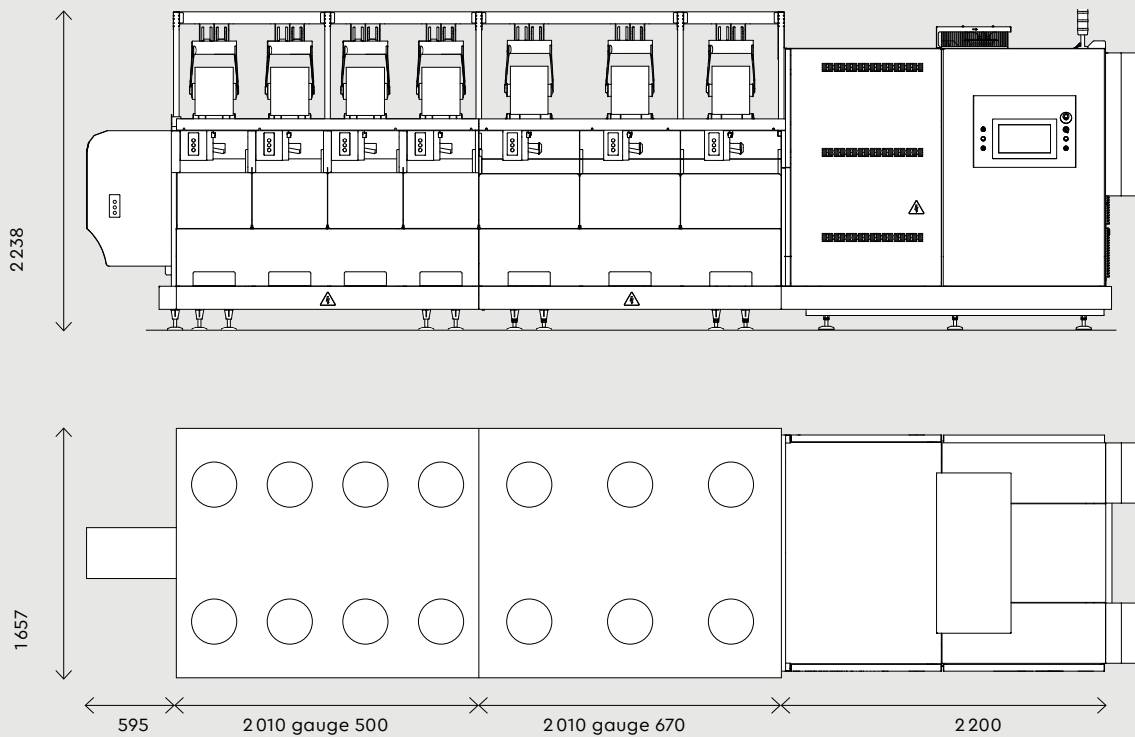

CableCorder CC5-TFO – gauge 500

Number of spindles	8	16	24	32	40	48	56	64	72	80	88
Machine length mm	4 805	6 815	8 825	10 835	12 845	14 855	16 865	18 875	20 885	22 895	24 905
Number of spindles	96	104	112	120	128	136	144	152	160		
Machine length mm	26 915	28 925	30 935	32 945	34 955	36 965	38 975	40 985	42 995		

Machine lengths without dimensions of cooling units; machine length with suction duct upwards: +700 mm per suction tower
With package slide option +395 mm

CableCorder CC5-TFO – gauge 670

Number of spindles	6	12	18	24	30	36	42	48	54	60	66
Machine length mm	4 805	6 815	8 825	10 835	12 845	14 855	16 865	18 875	20 885	22 895	24 905
Number of spindles	72	78	84	90	96	102	108	114	120		
Machine length mm	26 915	28 925	30 935	32 945	34 955	36 965	38 975	40 985	42 995		

Machine lengths without dimensions of cooling units
With package slide option +395 mm

CableCorder CC5 – Technical and textile data

		CableCorder CC5-TFO – gauge 500	CableCorder CC5-TFO – gauge 670
Spindle sizes	mm Ø/traverse	230/10", 230/12", 250/10", 250/12", 280/10"(F), 280/12"(F)	300/10", 300/12", 330/10", 330/12"
Number of spindles	max.	160	120
Spindle speed	rpm max.	2 000–11 900	
Range of twists	tpm	27–1 586	
Direction of twist		S or Z	
Delivery speed	m/min	15–150	
Materials		PA, PES, AR, CV (PES-HMLS, AR and CV with additional device)	
Range of counts	dtex	470–9 900 (depending on spindle size and gauge)	

(F)=Fine yarn count spindle

Additional devices:

Data interface OPC UA, quality sensor, package slide, air/water or air/refrigerant heat exchanger, noise abatement, suction upwards or downwards (gauge 500), equipment for processing rayon and aramid, Pineapple package build-up, assembling device, Campanello, thread reserve, UPS, remote diagnostics, Performance Indicator, Maintenance Indicator, Mill Management System Senses, tension meter, stroboscope, splicer

CableCorder CC5, CC5-Basic, CC5-3PLY, CC5-TFO

Feed packages	Ø 205 mm		Ø 230 mm		Ø 250 mm		Ø 290 mm		Ø 300 mm		Ø 330 mm	
	kg		kg		kg		kg		kg		kg	
Traverse 10"	PA	5	PA	7	PA	8.5	PA	12.2	PA	13.1	PA	16.3
	PES	6	PES	8	PES	9.8	PES	14.1	PES	15.2	PES	18.9
	CV	6.2	CV	8.5	CV	10.4	CV	14.7	CV	16	CV	19.9
	AR	6.2	AR	8.5	AR	10.4	AR	14.7	AR	16	AR	19.9
Traverse 12"			PA	8.2	PA	10.2	PA	14.5	PA	15.7	PA	19.5
			PES	9.5	PES	11.8	PES	17	PES	18.2	PES	22.6

Twist packages

Material	PA	PES	CV/AR	Single-twisted yarn
Traverse 10"	11.8 kg	13.0 kg	14.5 kg	17.5 kg
Diameter mm	350			

The weights are only approximate values, i.e. they may vary with the tube size and package density
PA = polyamide, PES = polyester, AR = aramid, CV = rayon

General notes

Research and development do not stand still. This can mean that one or another statement about the described product is superseded by technical progress. The illustrations have been selected according to informative aspects. They can also contain additional equipment that is not included in the standard scope of delivery. Our technical details in the offer and order confirmation are decisive for the binding machine design.

Saurer Technologies GmbH & Co. KG
Twisting Solutions
Weeserweg 60
47804 Krefeld
Germany
T +49 2151 717 01
sales.twisting@saurer.com

Saurer Technologies GmbH & Co. KG
Twisting Solutions
Leonhardstrasse 19
87437 Kempten
Germany
T +49 831 688 0
sales.twisting@saurer.com

Saurer Hong Kong
Machinery Co. Ltd.
Room 2803-5, 28/f, The Center
99 Queen's Road Central
Central
Hong Kong
T +852 2866 0308
jackson.ye@saurer.com

Saurer (Jiangsu)
Textile Machinery Co., Ltd.
Shanghai Branch Company
36F, Tower B, The HQ, 100 Zunyi Road
200051 Shanghai
China
T +86 21 2226 2578
TWI.SH.CN@saurer.com

Saurer (Jiangsu)
Textile Machinery Co., Ltd.
No.9, Chang Yang Street
Suzhou Industrial Park, 215024
Jiangsu Province
China
T +86 512 8188 5688
info.TWI.CN@saurer.com

Saurer Inc.
8801 South Boulevard
Charlotte, NC 28273
USA
T +1 704 916 42 72
Twisting.USA@saurer.com

saurer.com